



RAEGuard PID

4-20 mA PID Transmitter

The **RAEGuard PID** is a permanently mounted (fixed) Photoionization Detector (PID) transmitter that operates from a 9 to 36 VDC power source and provides an analog (4-20 mA) signal output in three full scale ranges* of 20 ppm, 100 ppm, or 1,000 ppm isobutylene equivalent. Housed in an explosion-proof enclosure, the **RAEGuard PID** is equipped with a local digital display of the gas concentration and functional keys for performing calibration.

Key Features

- 4-20 mA analog output ranging from 0.1 to 100.0 ppm, or 1 to 1,000 ppm isobutylene equivalent
- 4-20 mA analog output ranging from 0.01 to 20.00 ppm isobutylene equivalent for ultra-sensitive version

- Explosion-proof enclosure for hazardous locations
- Long life 10.6 eV Ultraviolet lamp and 3D Sensor
- Built-in pump with patented self-cleaning duty cycle operation
- Local displays with adjustment keys
- Magnetic key interface eliminates the need to open explosion proof housing when making calibration and other minor adjustments
- Operation at 9 to 36V DC
- Two dry contact outputs (<30V,2A)

Applications

- Waste water treatment plants
- Marine and off-shore oil wells
- Refineries & petrochemical plants
- Power plants
- Pulp and paper mills
- Solvent recovery systems
- Painting and coating operations
- Air quality



ATEX



RAE Systems Inc.
3775 North First Street, San Jose, CA • 95134 • USA
Tel: 877.723.2878 • Fax: 408.952.8480
Email: raesales@raesystems.com • www.raesystems.com

rev6_ 11.04

RAE Systems Europe
Orestads Boulevard 69, 2300 Copenhagen S • Denmark
Tel: +45.8652.5155

RAE Systems (Hong Kong) Ltd.
Room 8, 6/F, Hong Leong Plaza, 33 Lok Yip Road, Fanling, N.T. • Hong Kong
Tel: 852.2669.0828



Specifications *

Detector Specifications

Size	5.0"L x 5.0"W x 4.5"H (127mm x 127mm x 115mm)
Weight	5.5 lbs (2.5 kg)
Detector	3D PID sensor std. 10.6 eV lamp
Hazardous Location Classifications	<ul style="list-style-type: none"> • UL Class I, Div. 1, Groups B, C, D Temperature Code T6 • cUL Class I, Div. 1, Groups B, C, D Temperature Code T6 • ATEX, II 2 G EEx d IIB T6
Power	9-36 VDC max 125mA at 24V
Output	4-20mA
Sampling	Internal diaphragm pump
Display	7-segment, 4-digit LCD with 4 color-coded fault LEDs
Response Time (t90)	40 seconds to 90% of reading using isobutylene
User Interface	Magnetically accessed keys for calibration
Temperature	-20° to 55°C (-4 to 131°F)
Humidity	0 - 95% relative humidity (non-condensing)
Dry Contact	Max 30V, 2A
Mounting	2 holes 5.25" (133 mm) from center to center

*Ongoing projects to enhance our products means that these specifications are subject to change

RAEGuard PID

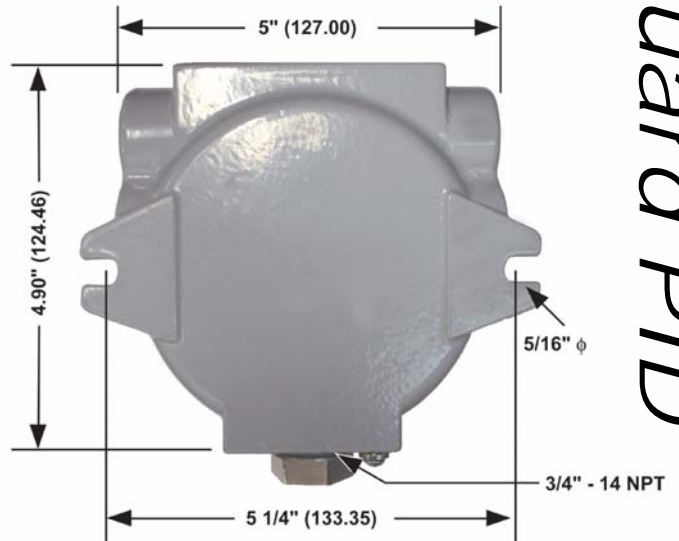

DISTRIBUTED BY: